

CAX1 CARRY ALL MANUAL

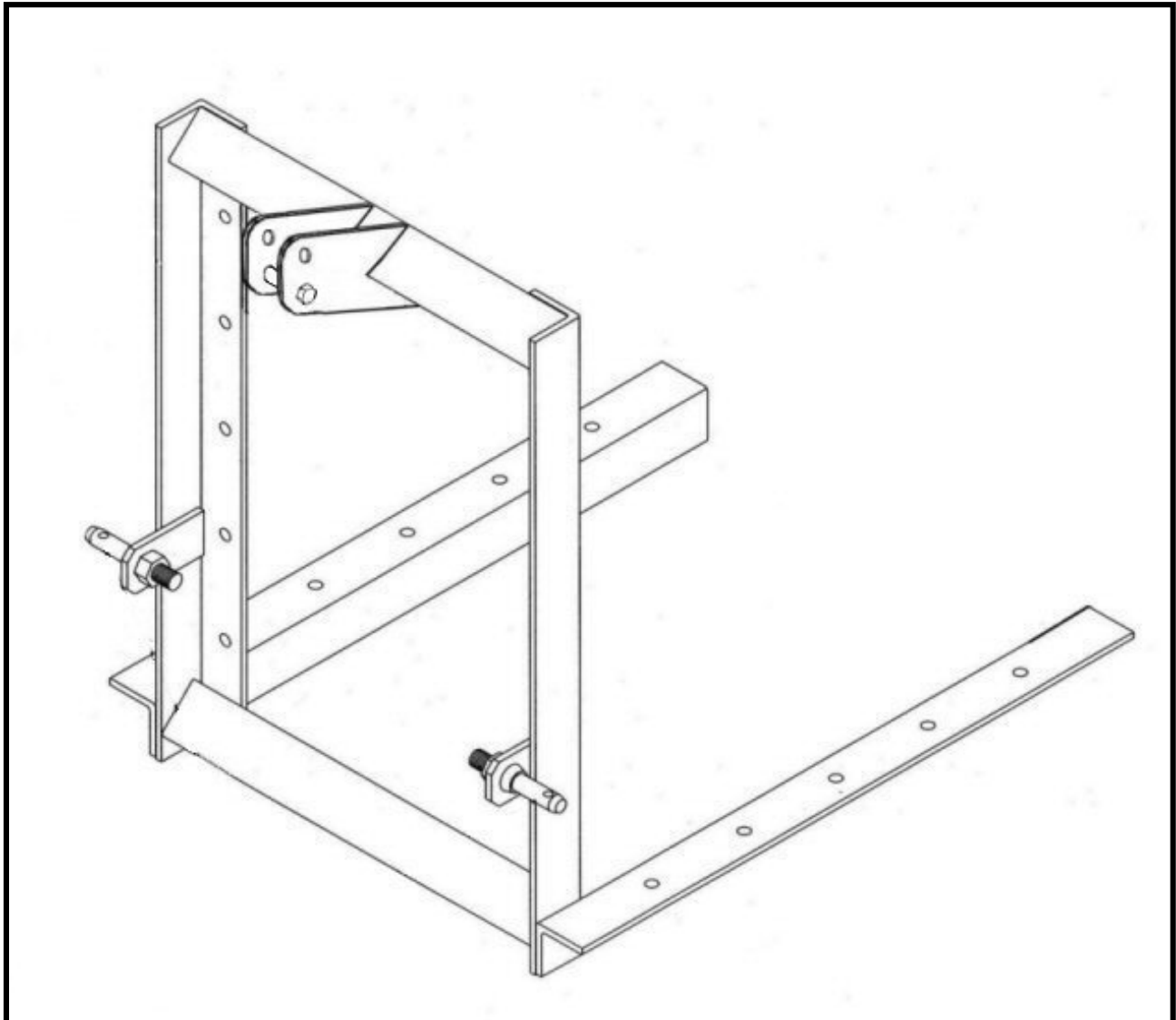

TO THE PURCHASER

This manual contains valuable information about your new Summit Tractor CAX1 carry all. It has been carefully prepared to give you helpful suggestions for operating, adjusting, servicing and ordering repair parts.

Keep this manual in a convenient place for quick and easy reference. Study it carefully. You have purchased a dependable and sturdy carry all, but only by proper care and operation can you expect to receive the service and long life designed and built into the product.

Sometime in the future your carry all may need new parts to replace those that are worn. If so, go to your dealer and provide him with the model and part number.

Customer Information

Name _____

Purchased From _____

Date Purchased _____

Model No. _____

Serial No. _____

It is the purchaser and/or operator's responsibility to....

I Read and understand the information contained in this manual.

I Operate, lubricate, assemble and maintain the equipment in accordance with all instructions and safety procedures in this manual.

I Inspect the equipment and replace or repair any parts that are damaged or worn which under continued operation would cause damage, wear to other parts, or cause a safety hazard.

I Return the equipment or parts to the authorized Summit Tractor dealer, from where it was purchased, for service or replacement of defective parts that are covered by warranty. (The Summit Tractor Factory or an Authorized Summit Tractor Dealer may inspect equipment or parts before warranty claims are honored.)

CONTENTS

ITEM	PAGE
Specifications	6
Safety	7
Safety Training	9
Preparation	10
Operational Safety	11
Assembly, Before Operation, Transport & Operation	13
Maintenance, Storage, Attaching & Detaching	14
Replacement Parts.....	15
Warranty	16

SPECIFICATIONS

MODEL	CAX1
CARRY ALL LENGTH	36"
CARRY ALL FRAME WIDTH	32-3/4"
CARRY ALL HEIGHT	36"
HITCH TYPE	CAT. I
FRAME	HD ANGLE IRON
APPROX. WEIGHT	97 LBS.



**FRAME HAS PRE-PUNCHED HOLES BUT
BOARDS ARE NOT INCLUDED**

SAFETY

READ AND FOLLOW THE INSTRUCTIONS IN THIS MANUAL AND ESPECIALLY IN THE SAFETY SECTION. FAILURE TO DO SO CAN RESULT IN SERIOUS INJURY OR DEATH.

TAKE NOTE! THIS SAFETY ALERT SYMBOL FOUND THROUGHOUT THIS MANUAL IS USED TO CALL YOUR ATTENTION TO INSTRUCTIONS INVOLVING YOUR PERSONAL SAFETY AND THE SAFETY OF OTHERS.



THIS SYMBOL MEANS
ATTENTION!
BECOME ALERT!
YOUR SAFETY IS INVOLVED

SIGNAL WORDS:

The signal words **DANGER**, **WARNING** and **CAUTION** are used with the safety messages in this manual and with each safety signs. They are defined as follows:

DANGER: Indicates an immediate hazardous situation that, if not avoided, could result in serious injury or death. This signal word is to be limited to the most extreme situations typically for machine components that, for functional purposes, cannot be guarded.

WARNING: Indicates a potentially hazardous situation that, if not avoided, could result in serious injury or death, and includes hazards that are exposed when guards are removed. It may also be used to alert against unsafe practices.

CAUTION: Indicates a potentially hazardous situation that, if not avoided, may result in minor or moderate injury. It may also be used to alert against unsafe practice.

If you have any questions not answered in this manual or require additional copies or the manual is damaged, please contact your dealer or Summit Tractor LLC 3379 Peachtree Road NE Suite 555 Atlanta, GA 30326 (678) 916-6555.

EQUIPMENT SAFETY GUIDELINES



- I Safety of the operator and bystanders is one of the main concerns in designing and developing a carry all. However, every year accidents occur which could have been avoided by a few seconds of thought and a more careful approach to handling equipment. You, the operator, can avoid many accidents by observing the following precautions and insist those working with you, or for you, follow them.
- I In order to provide a better view, certain photographs or illustrations in this manual may show an assembly with a safety shield removed. However, equipment should never be operated in this condition. Keep all shields in place. If shield removal becomes necessary for repairs, replace the shield prior to use.
- I Replace any safety sign that is not readable or is missing. Copies of such safety signs are shown in this manual.
- I Never use alcoholic beverages or drugs that can hinder alertness or coordination while operating this equipment. Consult your doctor about operating this machine while taking prescription medications.
- I **Under no circumstances should children under the age of 18 be allowed to work with this equipment. Do not allow persons to operate or assemble this unit until they have read this manual and have developed a thorough understanding of the safety precautions and of how it works. Review the safety instructions with all users annually.**
- I This equipment is dangerous to children and persons unfamiliar with its operation. The operator should be a responsible, properly trained and physically able person familiar with farm machinery and trained in this equipment's operations. If the elderly are assisting with farm work, their physical limitations need to be recognized and accommodated.
- I Use a tractor equipped with a Roll Over Protective System and seat belts. (ROPS)
- I Never exceed the limits of a piece of machinery. If its ability to do a job, or to do so safely, is in question- **DON'T TRY IT.**
- I Do not modify the equipment in any way. Unauthorized modification could result in serious injury or death and may impair the function and life of the equipment.
- I In addition to the design and the configuration of this implement, including safety signs and safety equipment, hazard control and accident prevention are dependent upon the awareness, concern, prudence, and proper training of personnel involved in the operation, transport, maintenance, and storage of the machine. Refer also to safety messages and operation instruction in each of the appropriate sections of the tractor and carry all manuals. Pay close attention to the safety signs affixed to the tractor and the carry all.

SAFETY TRAINING



- I Safety is a primary concern in the design and manufacture of our product. Unfortunately, our efforts to provide safe equipment can be wiped out by a single careless act of an operator or bystander.
- I In addition to the design and configuration of equipment, hazard control and accident prevention are dependent upon the awareness, concern, prudence and proper training of personnel involved in the operation, transport, maintenance and storage of this equipment.
- I It has been said, “The best safety device is an informed, careful operator.” We ask you to be that kind of operator. It is the operator’s responsibility to read and understand all safety and operating instructions in the manual and to follow them. Accidents can be avoided.
- I Working with unfamiliar equipment can lead to careless injuries. Read this manual, and the manual for your tractor, before assembly or operating, to acquaint yourself with the machines. If this machine is used by any person other than you, or is loaned or rented, it is the carry all owner’s responsibility to make certain that owner's manual be available to the operator prior to operating and that the operator:
 - 1- Reads and understands the operator’s manuals.
 - 2- Is instructed in safe and proper use.
- I Know your controls and how to stop tractor, engine, and the carry all quickly in an emergency. Read this manual and the one provided with your tractor.
- I Train all new personnel and review instructions frequently with existing workers. Be certain only a properly trained and physically able person will operate the machinery. A person who has not read and understood all operating and safety instructions is not qualified to operate the machine. An untrained operator exposes himself and bystanders to possible serious injury or death.

PREPARATION



- Always wear close fitting clothing and personal protection equipment called for by the job conditions. These items may include a hard hat, safety glasses, goggles or face shield, hearing protection and safety boots. DO NOT wear loose clothing, jewelry or any other items that may be entangled in moving parts. Tie up long hair.
- Ensure equipment is properly mounted, adjusted and in good operating condition.
- Tighten all bolts and nuts and check that all cotter pins are installed securely to ensure equipment is properly assembled before operating.
- Tractor must be equipped with an approved Roll-Over-Protective System (ROPS). Keep seat belt securely fastened. Falling off the tractor can result in serious injury or even death. Keep foldable ROPS systems in “locked up” position at all times.
- A minimum 20% of the combined tractor and equipment weight must be on the tractors front wheels with the equipment in transport position. Without this weight, tractor could tip over causing personal injury or death. See your tractors operators manual for information regarding adding weights.
- Remove accumulated debris from this equipment, tractor, and engine to avoid fire hazard.
- Ensure all safety decals are installed. Replace if damaged.

OPERATIONAL SAFETY



- . Operate only in daylight or good artificial light.
- . Always comply with all state and local lighting and marking requirements.
- . No riders on equipment.
- . Always sit in tractor seat with seat belt fastened when operating controls or starting engine. Place transmission in park or neutral, engage brake and ensure all other controls are disengaged before starting tractor engine.
- . Look down and to the rear and make sure area is clear before operating in reverse.
- . Do not operate on steep slopes.
- . Do not stop, start or change directions suddenly on slopes.
- . Watch for hidden hazards on the terrain during operation.
- . Stop implement and tractor immediately upon striking an obstruction. Turn engine off, remove key, inspect and repair any damage before resuming operation.
- . When performing any service or maintenance, disengage power to implement. Lower all raised components to the ground. Operate valve levers to relieve any hydraulic pressure. Shut off the engine, set the parking brakes and remove the ignition keys before dismounting tractor.
- . Keep all persons away from operator control area while performing adjustments, service or maintenance.

OPERATIONAL SAFETY *continued...*



- I Always stop the tractor, set brake, shut off the tractor engine, remove the ignition key, lower implement to the ground and allow everything to come to a complete stop before dismounting tractor. Never leave equipment unattended with the tractor running.
- I Never place hands or feet close to carry all with tractor engine running or before you are sure all motion has stopped. Stay clear of all moving parts.
- I Do not reach or place any part of your body close to equipment until it is blocked securely.
- I Do not allow riders on the tractor at anytime. There is no safe place for any riders.
- I Do not operate unless all personnel, livestock, and pets are several feet away to prevent injury.
- I The parts of this machine have been designed and tested for rugged use. However, they could fail upon impact with heavy, solid objects such as steel guardrails and concrete abutment. Such impact could cause the broken objects to be thrown outward. To reduce the possibility of property damage, serious injury, or even death, never allow the carry all to contact such obstacles.
- I Stop the carry all and tractor immediately upon striking an obstruction. Turn engine off, remove key, inspect and repair any damage before resuming operation.
- I Stay alert for uneven terrain, rocks, and roots and other hidden hazards. Keep away from drop-offs and hazards that could cause roll over. Use extreme care and maintain minimum ground speed when transporting or operating on hillsides, over rough ground and when operating close to ditches or fences. Be careful and slow down when turning sharp corners and changing direction on slopes. Do not start or stop suddenly on slopes. Avoid operation on steep slopes. In extremely uneven terrain, rear wheels weights, front tractor weight, and/or tire ballast should be used to improve stability.
- I Always check tractor manual for proper use on slopes.
- I When using a piece of equipment, a minimum 20% of tractor and equipment weight must be on tractor front wheels. Without this weight, tractor could tip over, causing personal injury or death. The weight may be attained with a front-end loader, front wheel weights, ballast in the tires or front tractor weights. When attaining a minimum 20% of tractor and equipment weight on the front wheels, you must not exceed the ROPS weight certification. Weigh the tractor and equipment. **Do not guess or estimate!**

ASSEMBLY

Your CAX1 carry all comes completely assembled..

The carry all comes with pre-punched holes which readily accept plywood or plank lumber to create a working platform, but the boards are not included.

BEFORE OPERATION

- 1) Tighten all loose hardware. Replace any missing hardware. On new machines, all hardware must be rechecked after first few hours of operation.
- 2) Replace any bent or broken parts.
- 3) Refer to your Tractor's Owner's Manual for recommended adjustments and weight distribution.
- 4) Check carry all for signs of wear or damage. Replace if necessary.
- 5) Read the SAFETY section of this manual to be sure of all precautions.

TRANSPORTING

- 1) Use a Slow - Moving - Vehicle (SMV) emblem and proper lighting on the tractor when transporting the carry all.
- 2) Always comply with all state and local lighting and marking requirements.
- 3) Do not drive the tractor and carry all over 20 MPH (30 KPH) on the best surface conditions. Reduce speed when going up or down hills and when approaching ditches or corners.
- 4) Check condition of hitch pins and frame before transporting.
- 5) Raise carry all to a safe position for transport.
- 6) Travel at a speed safe for terrain and other conditions.
- 7) Keep your carry all in proper working condition. Unauthorized modifications to the carry all may impair the function, affect the carry all life, and put you at risk. Do not add weight to carry all. Additional weight could cause frame to fail resulting in loss of control of carry all/tractor during transport.
- 8) Check local laws governing transport of farm equipment on public roads.
- 9) Use caution and be aware of oncoming traffic and roadside obstructions.
- 10) DO NOT transport on public roads at night.

OPERATION

Adjustments

Adjust top link so that the carry all is level. Then control the height of the carry all with tractor 3-point hitch.

ATTACHING



WARNING



Be sure bystanders are at a safe distance. Do not stand between carry all and tractor. Shut off tractor and engage parking brake prior to dismounting.

- 1) Back tractor to align 3-point hitch lower arms with carry all Cat. I lift pins.
- 2) Attach left lower link arm lift pin first and secure with click pin.
- 3) Using tractor right leveling crank, align right lower link arm with lift pin. Attach arm to lift pin and secure with click pin.
- 4) Attach top link between the top of the carry all frame and the tractor with a pin and secure with click pins.

DETACHING

- Lower carry all completely to the ground, taking all pressure of the lift pins.
- Shut off tractor engine and be sure that carry all is stable.
- Detach the tractor top link from the carry all.
- Detach tractor right hand lower link arm then left hand lower link arm from carry all.

MAINTENANCE

Your carry all is designed for minimum maintenance. By taking a few minutes prior to beginning operations and performing a maintenance check, you will insure improved performance and longer life of your carry all. Check all parts and frame structure then replace any parts that are worn, bent or broke.

STORAGE

- 1) Store on a level surface sheltered from the weather.
- 2) Sit carry all on a flat surface.
- 3) Clean all debris from carry all.
- 4) Keep children and bystanders away from storage area.
- 5) Keep stored away from livestock to prevent damage and/or injury.

CAX1 PARTS DIAGRAM

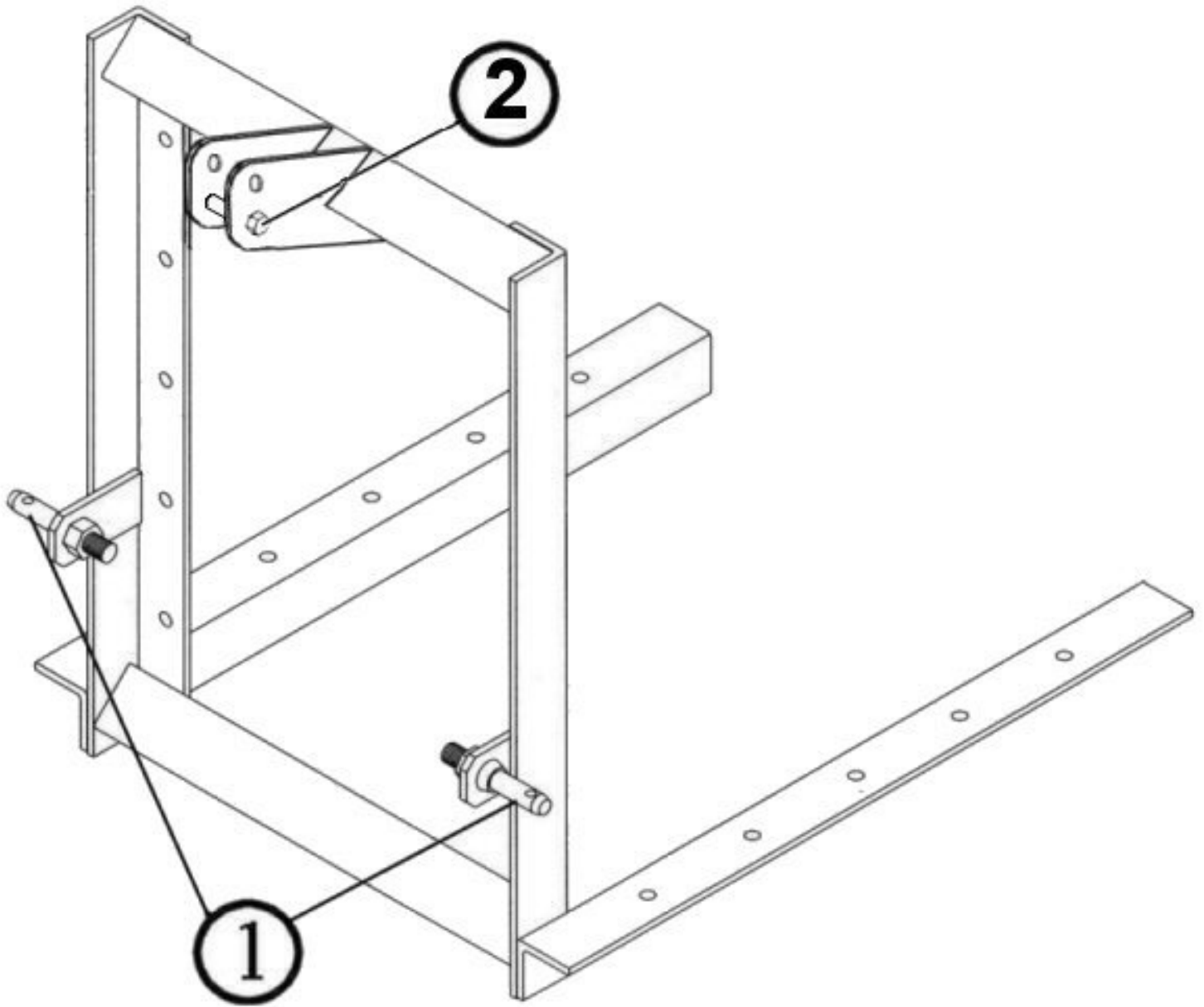

Ref. No.	Model #	Part #
		CAX1
1	Cat. 1 Lift Pins (Pkg. 2)	500001
2	Space Kit	504505



1. Limited Warranty.

Summit Tractors LLC, 3379 Peachtree Road NE Suite 555 Atlanta, GA 30326, warrants to the original retail purchaser ("Purchaser") that the product that is the subject of this sale is free from defects in material and workmanship at the time of sale.

Under this warranty, Summit Tractors will repair the defective product free of charge to the Purchaser, with either new or used and reconditioned replacement parts. All warranty service will be performed at service centers designated by Summit Tractors. If Summit Tractors is unable to repair the product to conform to the warranty after a reasonable number of attempts, Summit Tractors will provide, at its option, one of the following: (a) a replacement for the product or, (b) a full refund of the purchase price. Repair, replacement, or refunds are the Purchaser's EXCLUSIVE remedies against Summit Tractors under this limited warranty. Summit Tractors will not be liable for any special, incidental or consequential damages based upon breach or warranty, breach of contract, negligence, strict tort liability, or any other legal theory. Such damages include, but are not limited to, loss of profits, loss of savings or revenue, loss of use of the product or any associated equipment, cost of capital, cost of any substitute equipment, facilities or services, down time, the claims of third parties including customers, and injury to property. These limitations also apply, to the extent allowed by law, to personal injury.

The purchaser must notify the Seller in writing of any defect in material or workmanship within one (1) year following the date of purchase. If the equipment is used for commercial purposes, the Purchaser must notify the Seller in writing of any defect in material or workmanship within ninety (90) days following the date of purchase. In no event will Summit Tractors be liable under this warranty unless written notice is received by the Seller within one (1) year from the date of original retail sale.

2. Warranty of Title.

Summit Tractors warrants that it transfers a good title to the product free of any encumbrances, and free of the rightful claim of any third party for infringement of patent or copyright.

3. What is Not Covered by This Limited Warranty.

Summit Tractors will not be responsible for damage to or failure in the product which results from accident, misuse, abuse, neglect, installation of attachments not provided by Summit Tractors, modifications to the product, or damage caused by use of the product for purposes other than those for which it was designed.

4. No Other Warranties.

Unless modified in writing and signed by both parties, this agreement is understood to be the complete and exclusive agreement and warranty between Summit Tractors and Purchaser, superseding all prior agreements, oral and written, and all other communication between Summit Tractors and Purchaser related to the subject matter of this agreement.

THIS LIMITED WARRANTY IS IN LIEU OF ALL OTHER WARRANTIES, EXPRESS OR IMPLIED, INCLUDING, BUT NOT LIMITED TO, THE IMPLIED WARRANTY OF MERCHANTABILITY AND THE IMPLIED WARRANTY OF FITNESS FOR A PARTICULAR PURPOSE. No employee of Summit Tractors nor anyone else is authorized to make any warranty or representation in addition to or different from those made in this agreement.

5. Allocation of Risk.

This agreement allocates the risk of product failure between Summit Tractors and the Purchaser. This Allocation is recognized by both parties as reflected in the price of the goods. The Purchaser acknowledges that he or she has read this agreement, understands it, and is bound by its terms.